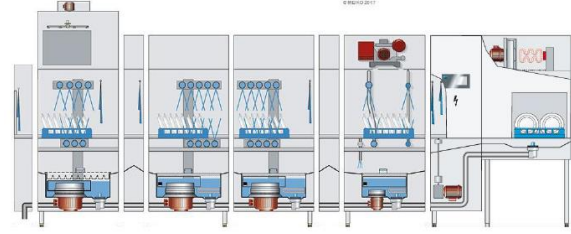
	<p><u>Manufacturer</u> MEIKO Maschinenbau GmbH & Co. KG</p>
	<p><u>Model no.</u> M-iQ K-L54 V8 N22 P8 TR90</p> <p><u>Product Description</u> M-iQ 4-tank Rack conveyor Dishwasher with 90 deg curve drying</p>
	<p><u>Origin</u> Offenburg, Germany</p>

SPECIFICATIONS

<p>Function</p>	<p>4-tank rack conveyor dishwasher with Pre-wash Zone, 2 x Main Wash Zone, Pump Final Rinse Zone and Drying Zone</p> <p>The function of the dishwasher is to provide the mechanical action necessary to distribute and direct the detergent solution and rinse waters over, under and around the dishes to loosen and remove soil. The dishwasher must also remove soil-laden waters from the machine and provide drying of dishes after the cleaning process has been completed. This should be done with the lowest consumption of fresh water, energy and chemical products</p>
<p>Form</p>	<p>Dimension : L 5195mm x D 945mm x H 2237(2415)mm Entry Height : 465mm Entry Width : 570mm Rack Size : 500 x 500mm</p>
<p>Construction</p>	<ul style="list-style-type: none"> - Heavy duty stainless steel construction with double insulated walls, 4 door springs per door with counterbalance and security switch - Revolutionary triple layer filter system in each tank - Cyclic Tank self-cleaning and active removal of food particles <i>during washing process</i> and continuous discharge by pump - Intelligent water level control of wash tanks through innovative pump & filter system - Unique opposite air flow concept avoid contaminated air and water mist entering the clean final rinse zone - Energy management concept including a heat recovery system with regulation of heating system and dynamic adaptation - Energy efficient air comfort drying by decoupled air flow - High pressure Bloc washing system with non-clogging wash nozzles and pump final rinse fully made of stainless steel 304 with optimal spray pattern geometry - self-emptying wash pump, impeller and manifold stainless steel 304 - High quality electric Control CC-Touch Glass panel display including data log diary (according DIN SPEC 10534)

	<ul style="list-style-type: none"> - Autotimer, Electronic tank over flow with water loss control, Detergent & rinse aid saving system - Automatic end of day self-cleaning cycle with only a single pump rinse section filling, including spray rinsing of heat recovery module - Variable adjustable conveyor speed
Engineering / MEP Ratings	<ul style="list-style-type: none"> - Voltage 400V/3NPE/50Hz - Connecting Load 41.0 kW - Nominal Current 71.0 A - Final rinse water consumption: 180 l/h - Water inlet connection: DN 20 - Combined single Drainage point connection: DN 70
Capacity	225 Basket/h with 2 min. water contact time according DIN SPEC 10534
Sanitation	<p>Entirely corresponds to the regulations of DIN SPEC 10534 for industrial dishwashing with multi-tank transport dish washing machines</p> <p>Main wash section(s) 55°C – 65°C Pump rinse section 60°C – 70°C Final rinse section 80°C – 85°C</p>
Accessories	<ul style="list-style-type: none"> - 3 x Universal basket VKV50/1 - 1 x basket for small pieces VKV 50/2 - Connection kit - BMS module CC Insight/CC log (Optional)
Safety	<ul style="list-style-type: none"> - CE (European Standard) - DIN SPEC 10534
Special Requirement	<ul style="list-style-type: none"> - Water Hardness max. 3°dh or approx. 50 ppm - Direct or indirect exhaust air connection is not necessary - On site general room ventilation need to be guaranteed