

M-iClean UM – Undercounter glasswasher

All MEIKO dishwashing machines are designed and built to provide maximum efficiency. That's what customers expect – and that's exactly what they get. But the M-iClean goes even further. Equipped with the full spectrum of innovative warewashing technology, the M-iClean's intuitive operating concept ensures maximum efficiency and reliability.

Execution for: Saudi Arabia Glasswasher

Fresh water line: Soft warm water 0-3°dH
 3-phase current: 3N PE 400V 60Hz
 Thermolabel

Technical data

Rack capacity/h (theoretical)	40 / 30 / 20 racks/h
Programme cycle	90 / 120 / 180 s
Rack dimension	500 x 500 mm
Entry height	315 mm
Dimensions (W x Hmin x D)	600 x 700 x 600 mm

Electrical feeding cable	3-phase current 3N PE 400V 60Hz*
	Total connected load: 11.4 kW
	max. rated current: 19.6 A

Local fuse protection	25 A
Machine protection class	IP X5

Equipment	Control system MIKE CPU4 Bluetooth interface for wireless communication Leakage detector Boiler safety device Automatic self-cleaning when tank is drained Thermolabel
------------------	---

Fresh water line	Air gap 'AB' in accordance with EN 1717 with booster pump
-------------------------	---

Fresh water supply	Minimum flow pressure 60 kPa / 0.6 bar in front of solenoid valve Maximum pressure: 500 kPa / 5.0 bar Max. supply water temperature 60 °C
---------------------------	---

Flow rate	3 l/min
------------------	---------

Final rinse water quantity	2.4 liters/cycle, variable
-----------------------------------	----------------------------

Boiler	Contents: 7.9 l Heater: 6.00 kW Temperature: 83 °C
---------------	--

Wash tank	Filling: 11.0 l Heater: 4.50 kW Temperature: 74 °C
------------------	--



Wash pump, with frequency converter	Performance: 0.50 kW
Dosing of rinse aid	Hose pump (24 V) with time control and suction lance
Detergent dosage	Hose pump (24 V) with time control and suction lance
Material	Cladding: 1.4301 Wash tank: 1.4301 Boiler: 1.4571
Heat emission	for 10 programme cycles/h total: 1.1 kW perceptible: 0.7 kW latent: 0.4 Kw
Ventilation flow rate	270 m ³ /h
Steam emission	0.5 kg/h
Emission sound pressure level at the workplace (LpA)	60 dB
Net / gross weight	63.0 kg / 74.8 kg (standard packaging)
Packaging dimensions (W x H x D)	700 x 1050 x 700 mm (standard packaging)

*Note:
Electrical equipment suitable for supply voltage:
3N PE 400 V 60 HZ (3N PE 380-415 V 60 Hz)
1N PE 230 V 60 HZ (1N PE 220-240 V 60 Hz)

1.0	machine connection: drain connection hose, DN 22 hose fitted as odour trap in interior of machine
1.1	drain (max. 700 mm above finished floor level), DN 50
2.0	Machine connection: fresh water supply, G 3/4"
2.1	Soft warm water 45-60°, DN 15, G 3/4 a max. 0,54 mmol/l CaCO ₂ (max. 3°dH) Flow rate: 3 l/min Minimum flow pressure: 60 kPa / 0.6 bar in front of solenoid valve Maximum pressure: 500 kPa / 5.0 bar stopcock and fine screen ≤ 25 µm
3.0	Machine connection: electrical connection cable 5G 4mm ²
3.1	electricity supply to the machine: 3N PE 400V ~ 60Hz nominal current / - capacity: 19.6 A / 11.4 kW Fuse protection: 25 A ⚡ Voltage equalising cable The master switch must be provided on site Note: Electrical equipment suitable for supply voltage: 3N PE 380-415 V 60 Hz / 1N PE 220-240 V 60 Hz
6.0	Heat load of warewash area
6.1	for 10 programme cycles/h total 1.1 kW, perceptible 0.7 kW, latent 0.4 kW
all cables, pipes etc leaving machine 1,6 m	
the position of the connection piping can also be mirror-inverted!	
Machine Equipment	
(A) Entry height	
Final rinse dosing unit with suction lance (blue connector)	
Detergent dosing unit and suction lance	
Thermolabel	

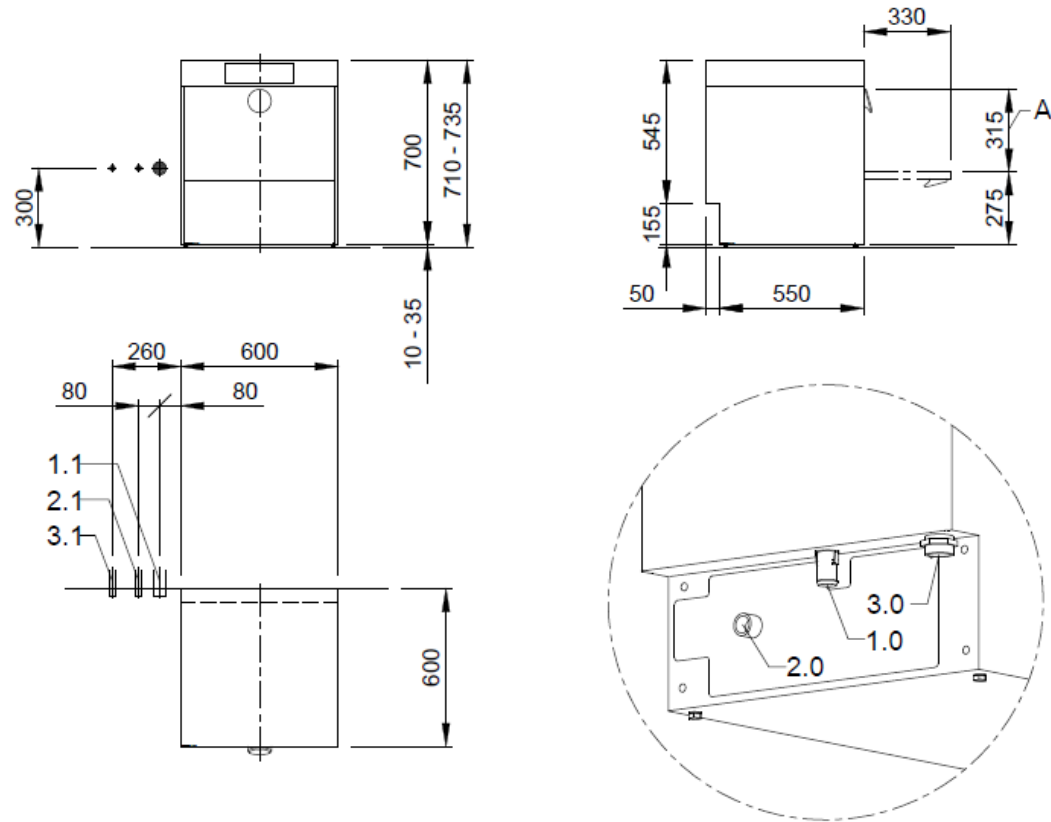

 <p>MEIKO MIDDLE EAST FZE GoldDiamond Park, Building#6, office #206 P.O. Box 282365, U.A.E.-Dubai Phone +971 43 41 51 72 E-MAIL: wat@meiko.de</p> <p>This drawing may not be neither passed to third parties for their information or copied or used for competitive purposes without our consent. All rights reserved. We reserve the right to make changes resulting from technical progress. This drawing was computer generated and is not subject to the checking and any release process; it is also not subject to change management. Please note: This document is only valid in conjunction with the conditions defined in Supplementary Sheet "Important Information". These can be requested from the manufacturer or downloaded from the Partnernet.</p>	Revision		
	Reference	DISHWASHER STANDARD DRAWING / SAU	
	Type	M-ICLEAN UM M2	
	TYPE: CROCKERY	THERMOLABEL	
Drawing-No.	S00079465		Order-No.
Scale	drawn:	23.04.2020 m-iplan	checked:
1:25			23.04.2020 m-iplan

MP000406117.2.2

©COPYRIGHT by MEIKO

SAU

EN

©COPYRIGHT by MEIKO